

David L. Trumper, Roberto J. Meléndez, Zhen Sun, Mohammad Imani-Nejad
MIT Department of Mechanical Engineering, Cambridge, MA 02139

Current Impact

The labs presented are currently being used in the MIT course 2.14 “Analysis and Design of Feedback Control Systems”. For their weekly assignment students have to demonstrate their working hardware to the staff as well as answer questions which test their understanding of the lab.

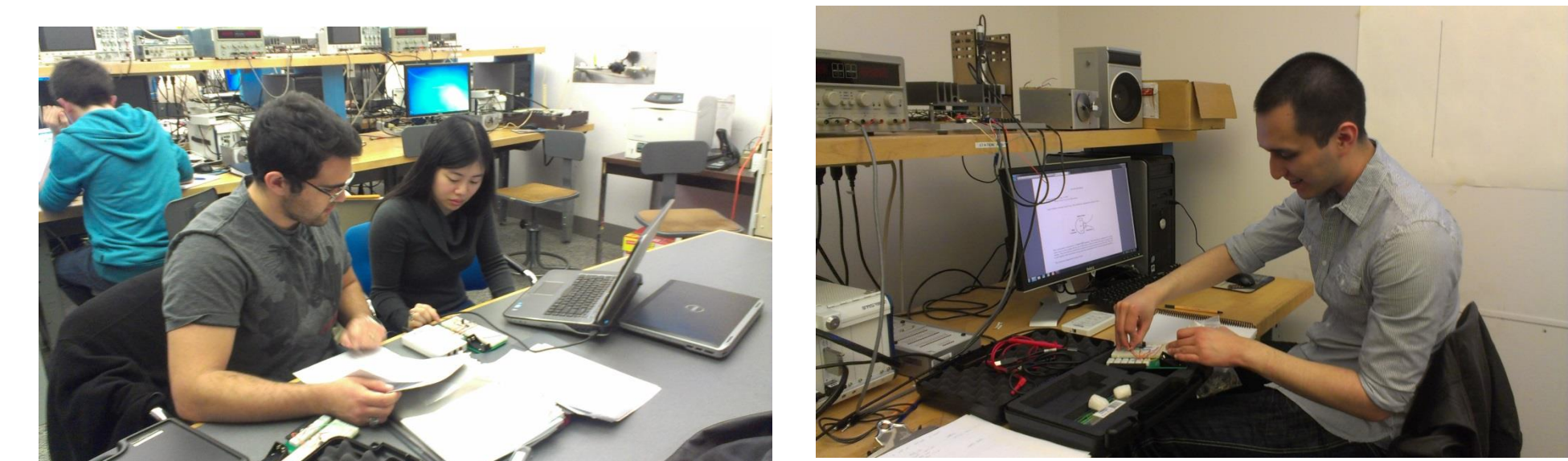

Future Work

More portable labs are under development. One example is a mechanical system consisting of a cantilever demonstrating second order dynamics. Another possibility in the longer term is to make a portable magnetic levitation lab.



Acknowledgements

The authors would like to thank National Instruments for their generous donation of hardware and software as well as their support during the development of these modules.

Introduction

Hands-on laboratory components are crucial for students to grasp the concepts of control systems effectively. However students might not have the opportunity to take part in such labs because of time scheduling and/or equipment constraints. Using the National Instrument MyDAQ as a fundamental building block, the Precision Motion Control Laboratory has developed portable control systems labs. Students can now take the lab hardware home and complete experiments in their dorm room, thus avoiding the normal time constraints of a 2 or 3 hour weekly lab period. The MyDAQ allows the students to utilize a function generator, oscilloscope and even a dynamic signal analyzer in the comfort of their dorm room.

NI MyDAQ

Virtual Tools:

Function Generator
Oscilloscope
Dynamic Signal Analyzer
Multimeter

Specs:

200kHz Sampling Rate
~100Hz Real Time Control Rate
2 D/A Channels
2 A/D Channels
Audio in/Audio Out
8 Digital Inputs/Outputs



Op-Amp Labs

As introduction to the myDAQ students build op-amp based controllers and measure their responses using myDAQ.

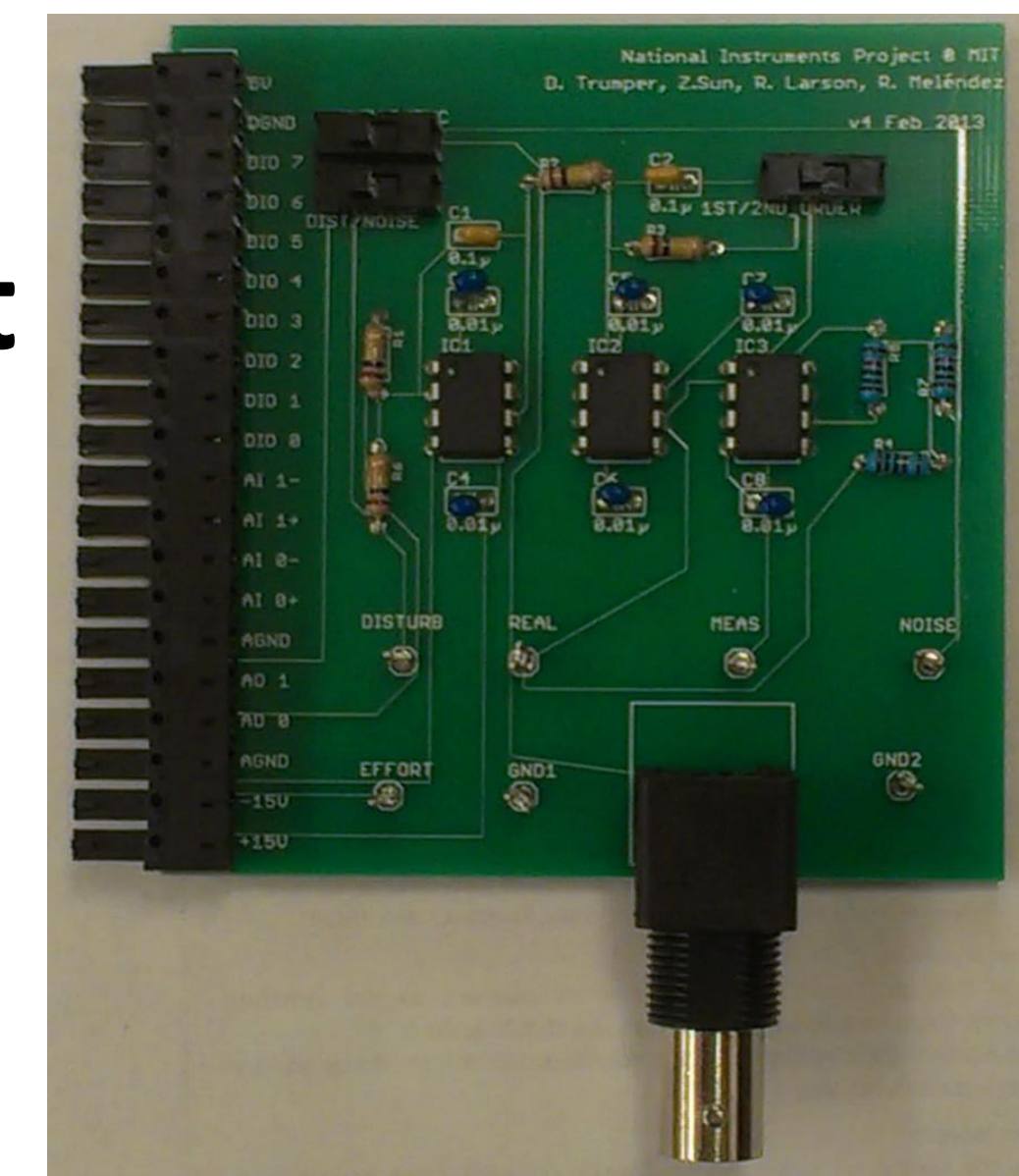
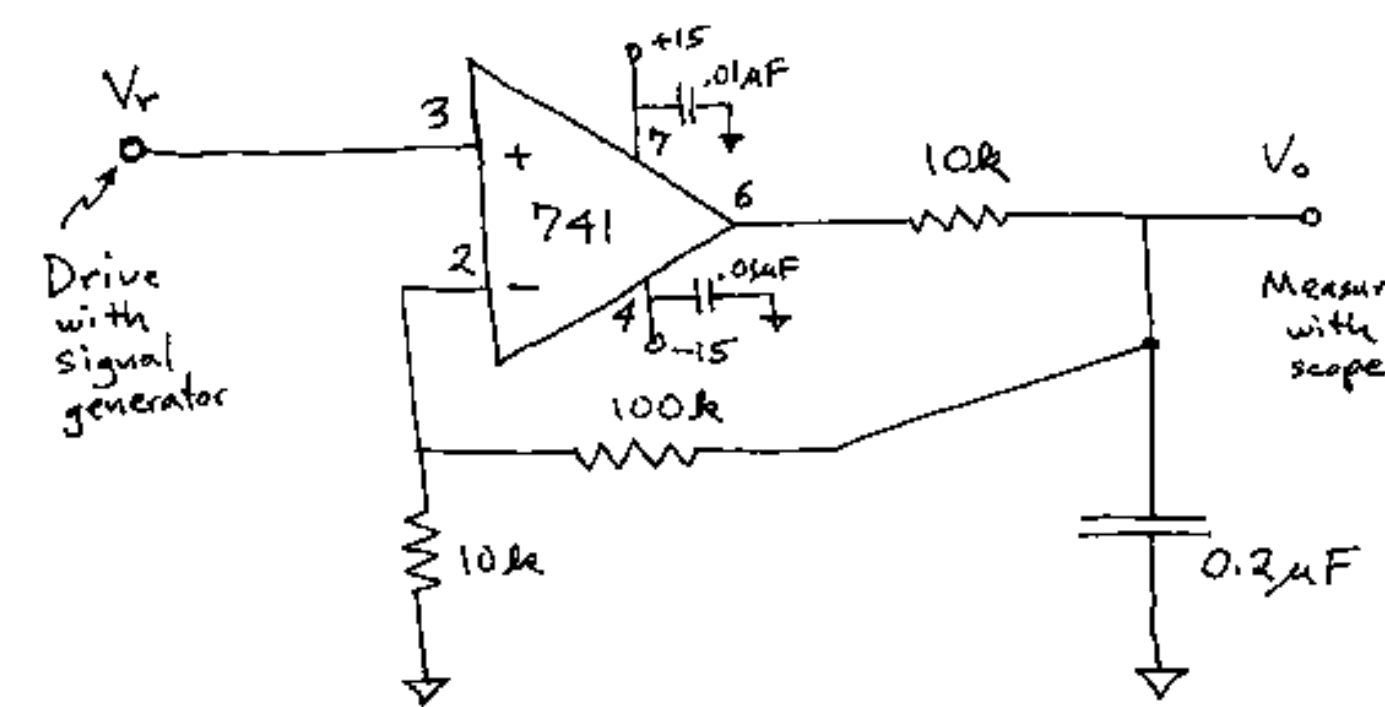
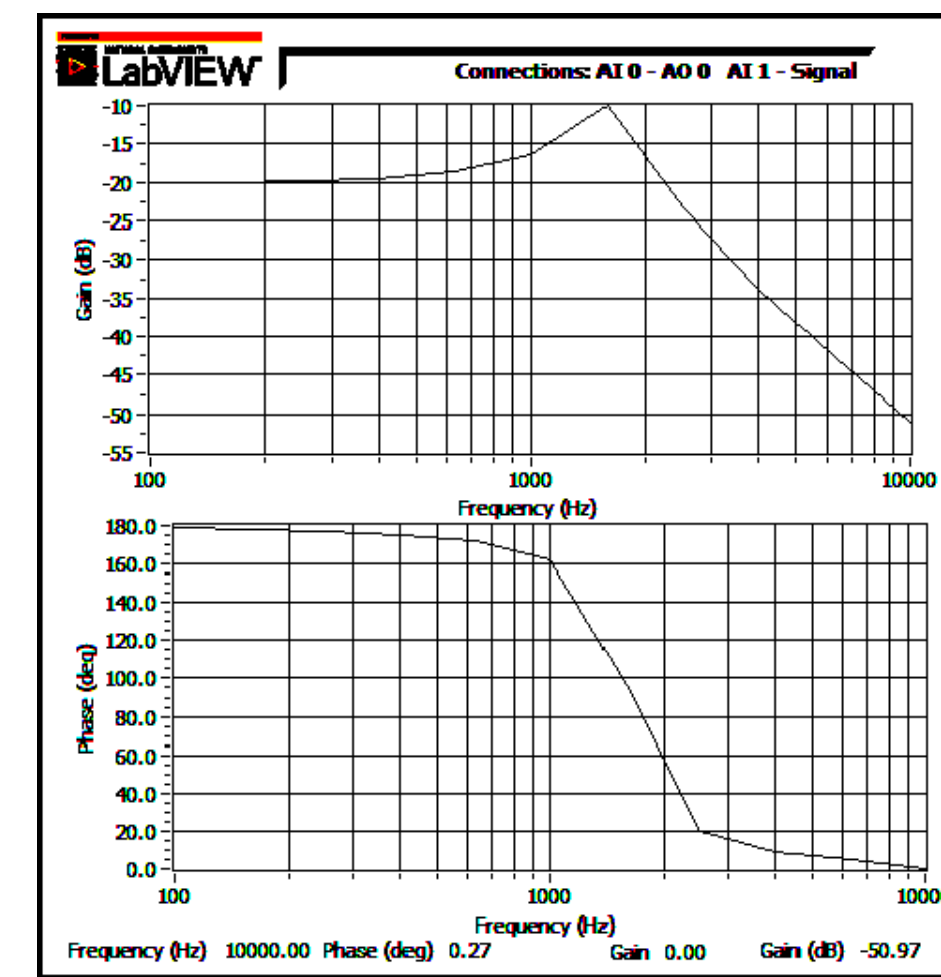

Double Integrator Plant

Students can toggle between a single and double integrator plant to control. Effects of noise and disturbances can be examined.

Thermal System

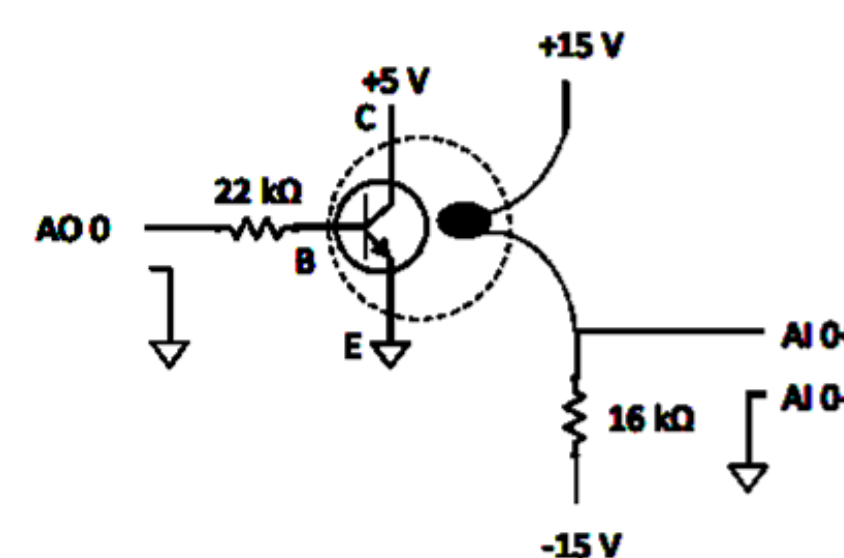

This lab studies the temperature control of a thermal mass. The heating element is a Bipolar Junction Transistor and the feedback is provided by a thermistor.

